

THIS DRAWING IS UNPUBLISHED. RELEASED FOR PUBLICATION 20
 © COPYRIGHT 20 BY - ALL RIGHTS RESERVED.

LOC		DIST		REVISIONS			
P	LTR	DESCRIPTION		DATE	DWN	APVD	
	B	REVISED PER ECR-15-006219		30APR2015	NK	JR	

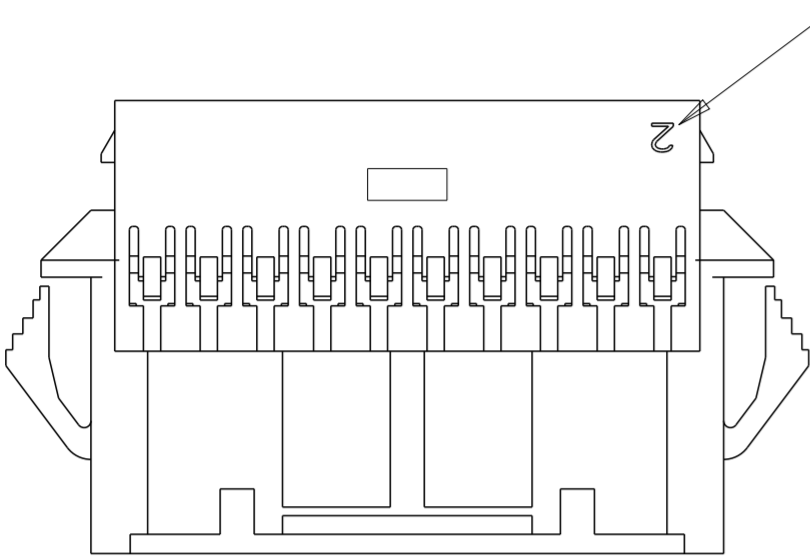

1-1969594-8 THROUGH 4-1969594-0
DOUBLE LATCH

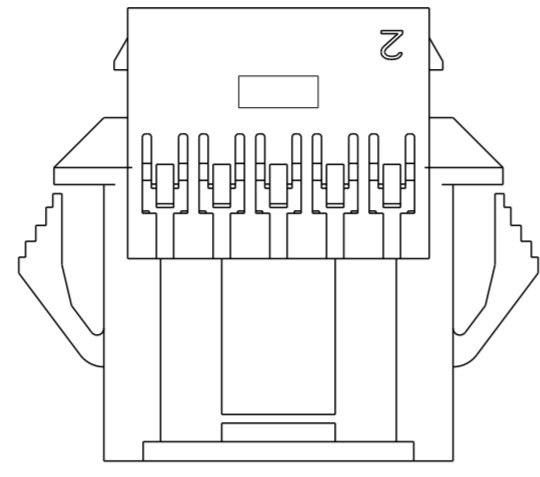

1969594-8 & 1-1969594-0
SINGLE LATCH W/O CUTOUTS

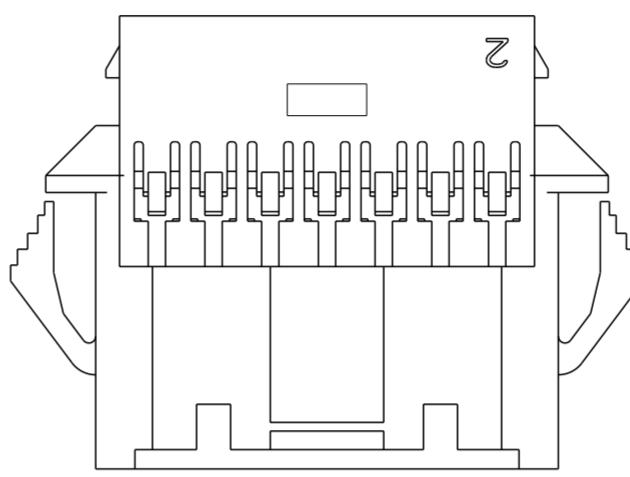

1-1969594-2, 1-1969594-4 & 1-1969594-6
SINGLE LATCH W/ CUTOUTS

1. MATERIAL: NYLON UL94 - V0
COLOR: WHITE
2. ACCEPTS TE PIN CONTACTS
P/N'S 2238007-() & 2238008-()
3. HOUSING ACCEPTS OPTIONAL TPA
P/N'S 1969541-()
4. MATES WITH TE PLUG HOUSINGS
P/N'S 1969540-()

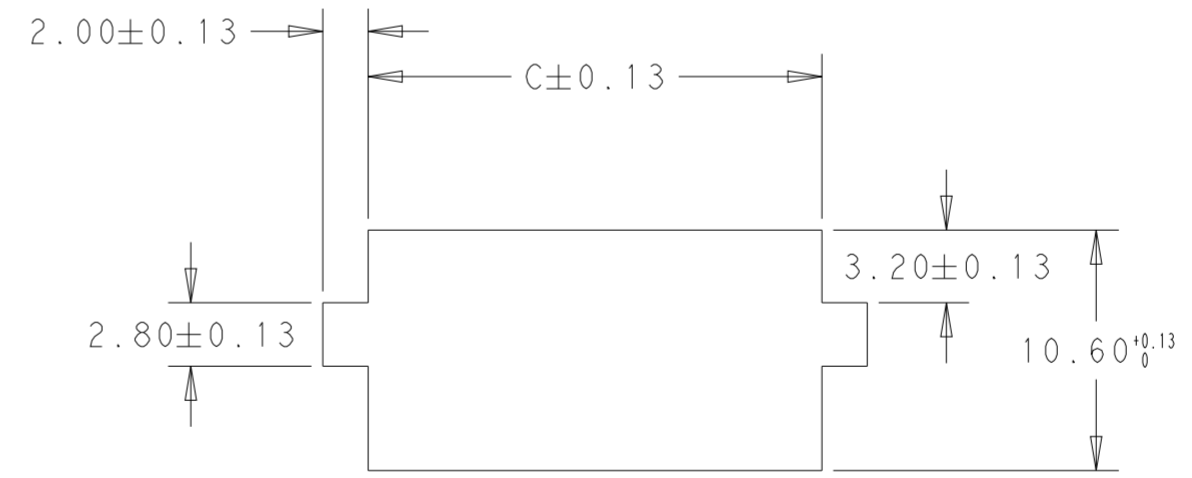
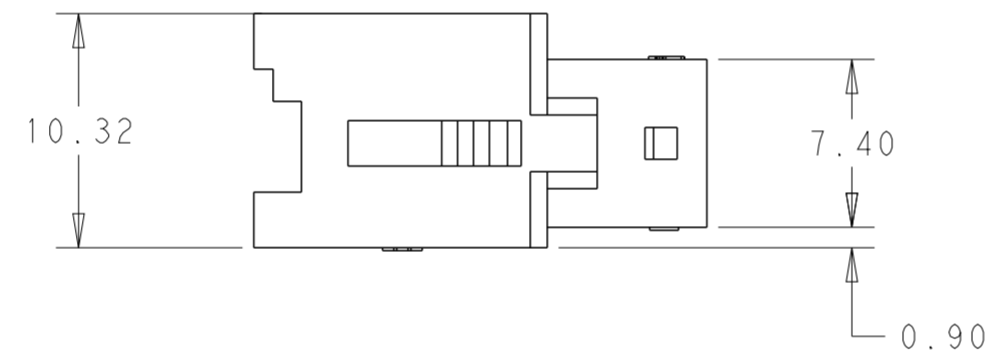
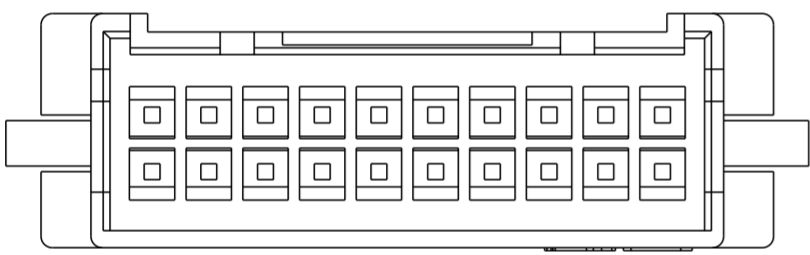

RECOMMENDED PANEL CUTOUT DIMENSIONS

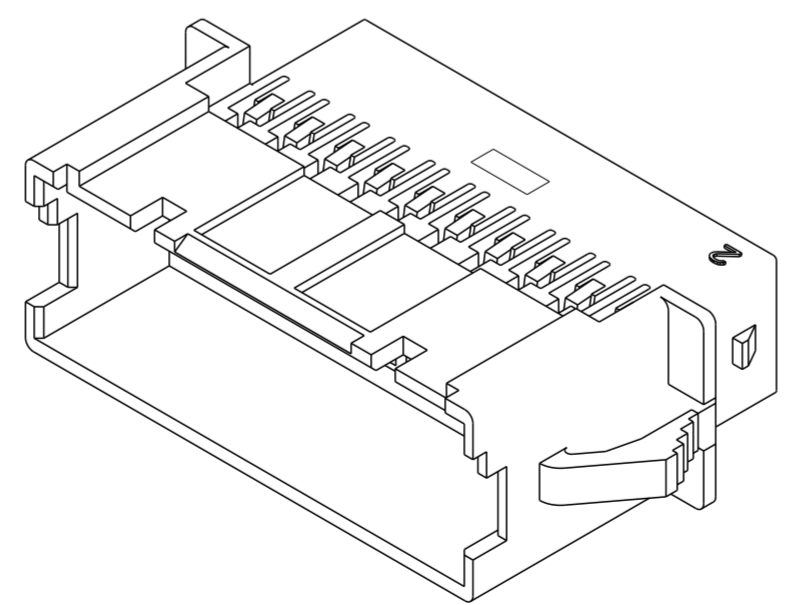
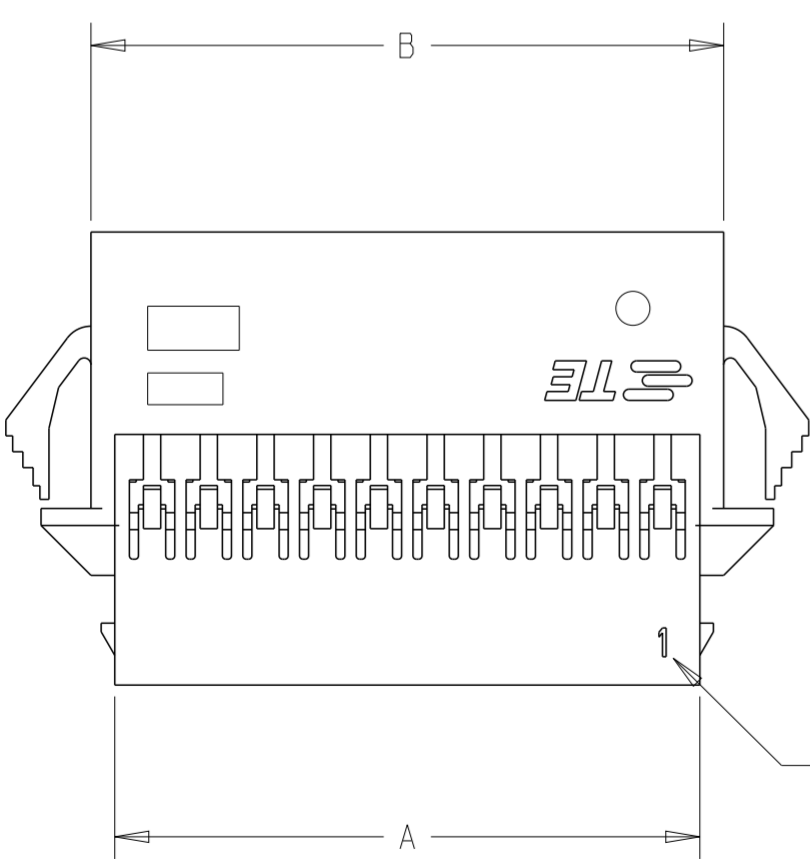

POS	DIM.C	DIM.B	DIM.A	PART NO.
40	54.50	52.89	50.79	4-1969594-0
38	52.00	50.39	48.29	3-1969594-8
36	49.50	47.89	45.79	3-1969594-6
34	47.00	45.39	43.29	3-1969594-4
32	44.50	42.89	40.79	3-1969594-2
30	42.00	40.39	38.29	3-1969594-0
28	39.50	37.89	35.79	2-1969594-8
26	37.00	35.39	33.29	2-1969594-6
24	34.50	32.89	30.79	2-1969594-4
22	32.00	30.39	28.29	2-1969594-2
20	29.50	27.89	25.79	2-1969594-0
18	27.00	25.39	23.29	1-1969594-8
16	24.50	22.89	20.79	1-1969594-6
14	22.00	20.39	18.29	1-1969594-4
12	19.50	17.89	15.79	1-1969594-2
10	17.00	15.39	13.29	1-1969594-0
8	14.50	12.89	10.79	1969594-8

THIS DRAWING IS A CONTROLLED DOCUMENT.

DWN A NOEL 28SEP2012
 CHK K RANDOLPH 01OCT2012
 APVD K RANDOLPH 01OCT2012

TE Connectivity

NAME EP 2.5 DUAL ROW, RECEPTACLE HSG
 WIRE TO WIRE, PANEL MOUNT

PRODUCT SPEC 108-2418
 APPLICATION SPEC 114-13315

SIZE A2 CAGE CODE 00779 DRAWING NO C-1969594 RESTRICTED TO -
 SCALE 3:1 SHEET 1 OF 1 REV B

MATERIAL SEE NOTES
 DIMENSIONS: mm
 TOLERANCES UNLESS OTHERWISE SPECIFIED:
 0 PLC ±
 1 PLC ±
 2 PLC ±0.20
 3 PLC ±
 4 PLC ±
 ANGLES ±
 FINISH ±

Customer Drawing